

**PRELIMINARY**

**PM50CLA060**

FLAT-BASE TYPE  
INSULATED PACKAGE

Notice : This is not a final specification. Some parametric limits are subject to change.

PM50CLA060

|      |                              |      |  |
|------|------------------------------|------|--|
| Pre. | <i>T. Marumo</i>             | Rev. |  |
| Apr. | <i>A. Tabata 30-Aug. '02</i> |      |  |

**Feature**

- a) Adopting new 5th generation IGBT(CSTBT) chip, which performance is improved by 1 $\mu$ m fine rule process.  
For example, typical  $V_{ce(sat)}=1.5V @T_j=125^{\circ}C$
- b) Adopt the over-temperature conservation by  $T_j$  detection of CSTBT chip, and error output is possible from upper arm and a lower arm of IPM at all each protection.
- c) New small package  
Reduce the package size by 32%, thickness by 22% from S-DASH series.

OUTLINE DRAWING Dimensions in mm

See Page 7

- 3 $\phi$  50A, 600V Current-sense IGBT type inverter
- Monolithic gate drive & protection logic
- Detection, protection & status indication circuits for, short-circuit, over-temperature & under-voltage (P-Fo available from upper arm devices)
- Acoustic noise-less 3.7kW class inverter application

APPLICATION : General purpose inverter, servo drives and other motor controls

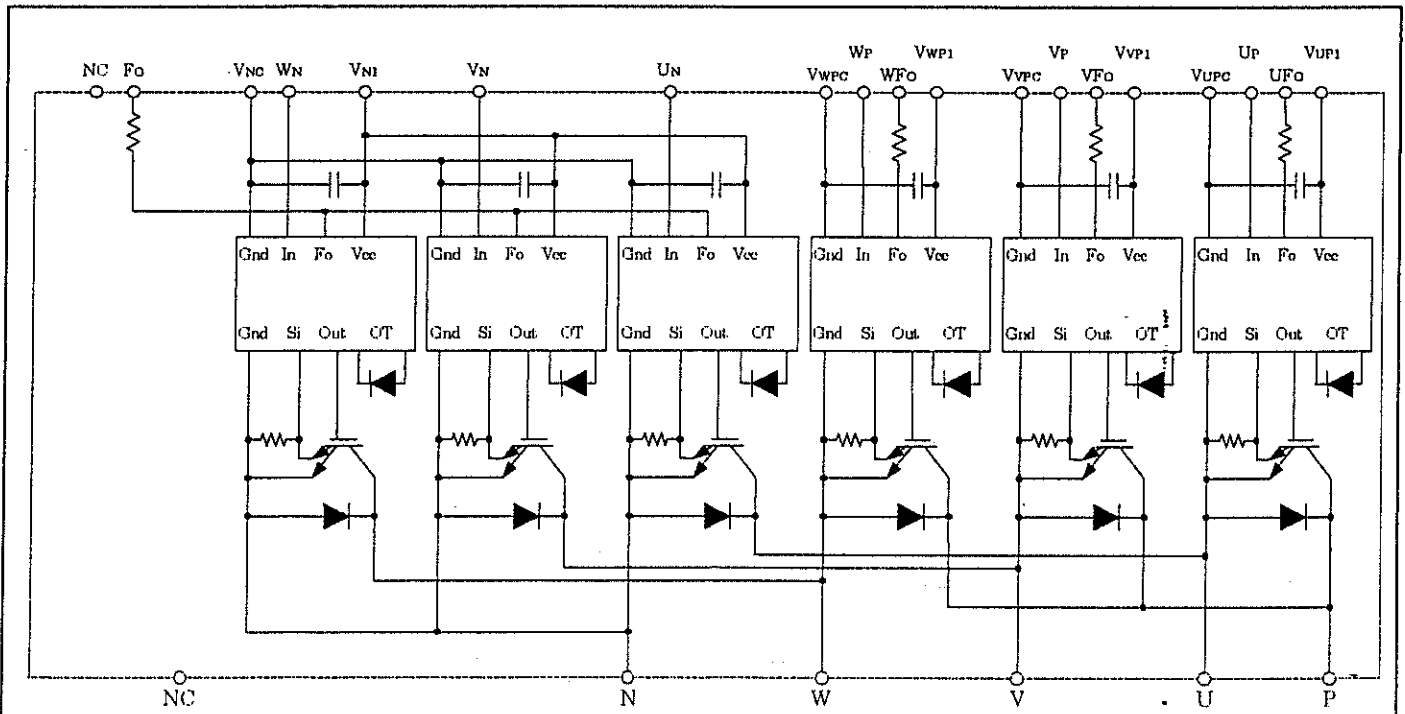

Maximum Ratings ( $T_j = 25^\circ\text{C}$ , unless otherwise noted)

## Inverter Part

| Item                      | Symbol       | Condition                                | Ratings    | Unit             |
|---------------------------|--------------|--|------------|------------------|
| Collector-Emitter Voltage | $V_{CES}$    | $V_D = 15\text{V}, V_{CIN} = 15\text{V}$ | 600        | V                |
| Collector Current         | $\pm I_C$    | $T_C = 25^\circ\text{C}$                 | 50         | A                |
| Collector Current (Peak)  | $\pm I_{CP}$ | $T_C = 25^\circ\text{C}$                 | 100        | A                |
| Collector Dissipation     | $P_C$        | $T_C = 25^\circ\text{C}$                 | 134        | W                |
| Junction Temperature      | $T_j$        |  | -20 ~ +150 | $^\circ\text{C}$ |

## Control Part

| Item                        | Symbol    | Condition  | Rating | Unit |
|-----------------------------|-----------|--|--------|------|
| Supply Voltage              | $V_D$     | Applied between : $V_{UP1}-V_{UPC}$<br>$V_{VP1}-V_{VPC}, V_{WP1}-V_{WPC}, V_{UN1}-V_{UNC}$ | 20     | V    |
| Input Voltage               | $V_{CIN}$ | Applied between : $U_P-V_{UPC}, V_P-V_{VPC}$<br>$W_P-V_{WPC}, U_N-V_N-W_N-V_{NC}$          | 20     | V    |
| Fault Output Supply Voltage | $V_{FO}$  | Applied between : $U_{FO}-V_{UPC}, V_{FO}-V_{VPC}$<br>$W_{FO}-V_{WPC}, F_O-V_{NC}$         | 20     | V    |
| Fault Output Current        | $I_{FO}$  | Sink current at $U_{FO}, V_{FO}, W_{FO}, F_O$ terminals                                    | 20     | mA   |

## Total System

| Item                              | Symbol          | Condition  | Rating     | Unit             |
|-----------------------------------|-----------------|--|------------|------------------|
| Supply Voltage Protected by SC    | $V_{CC(prot)}$  | $V_D = 13.5\sim 16.5\text{V}$<br>Inverter Part, $T_j = +125^\circ\text{C}$ Start | 400        | V                |
| Supply Voltage (Surge)            | $V_{CC(surge)}$ | Applied between : P-N, Surge value   | 500        | V                |
| Module Case Operating Temperature | $T_C$           | (Note-1)   | -20 ~ +100 | $^\circ\text{C}$ |
| Storage Temperature               | $T_{stg}$       |  | -40 ~ +125 | $^\circ\text{C}$ |
| Isolation Voltage                 | Viso            | 60Hz, Sinusoidal<br>Charged part to Base, AC 1 min.                              | 2500       | Vrms             |

(Note-1)  $T_c$ (under the chip) measurement point is below. (unit : mm)

| arm<br>axis | UP   |      | VP   |      | WP   |      | UN   |      | VN   |      | WN   |      |
|-------------|------|------|------|------|------|------|------|------|------|------|------|------|
|             | IGBT | FWDi | IGBT | FWDi | IGBT | FWDi | IGBT | FWDi | IGBT | FWDi | IGBT | FWDi |
| X           | 29.0 | 29.5 | 64.6 | 65.1 | 85.9 | 86.4 | 38.1 | 37.6 | 54.8 | 55.3 | 76.1 | 75.6 |
| Y           | -7.3 | 1.6  | -7.3 | 2.1  | -7.3 | 2.1  | 5.3  | -4.6 | 5.3  | -4.6 | 5.3  | -4.6 |

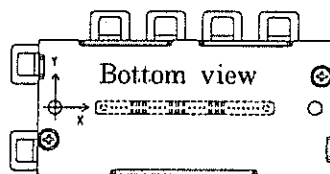

## Thermal Resistances

| Item                       | Symbol        | Condition   | Min. | Typ. | Max.  | Unit               |
|----------------------------|---------------|---|------|------|-------|--------------------|
| Junction to case           | $R_{th(j-c)}$ | Inverter IGBT part (per 1/6) (Note-1)                 | —    | —    | 0.93* | $^\circ\text{C/W}$ |
| Thermal Resistances        | $R_{th(j-f)}$ | Inverter FWDi part (per 1/6) (Note-1)                 | —    | —    | 1.60* |                    |
| Contact Thermal Resistance | $R_{th(c-f)}$ | Case to fin, (per 1 module)<br>Thermal grease applied | —    | —    | **    |                    |

\* If you use this value,  $R_{th(f-a)}$  should be measured just under the chips.

\*\*: This value is not specified yet.

Electrical Characteristics (T<sub>j</sub> = 25°C unless otherwise noted)

## Inverter Part

| Item                                 | Symbol               | Condition   | Min.                   | Typ. | Max. | Unit |    |
|--------------------------------------|----------------------|---|------------------------|------|------|------|----|
| Collector-Emitter Saturation Voltage | V <sub>CE(sat)</sub> | V <sub>D</sub> = 15V, V <sub>CIN</sub> = 0V<br>I <sub>C</sub> = 50A, Pulsed Fig.1   | T <sub>j</sub> = 25°C  | —    | 1.5  | 2.0  | V  |
|                                      |                      |   | T <sub>j</sub> = 125°C | —    | 1.5  | 2.0  |    |
| FWDi Forward Voltage                 | V <sub>EC</sub>      | I <sub>C</sub> = 50A, V <sub>CIN</sub> = 15V<br>V <sub>D</sub> = 15V Fig.2  | —                      | 2.2  | 3.3  | V    |    |
| Switching Time                       | t <sub>on</sub>      | V <sub>D</sub> = 15V, V <sub>CIN</sub> = 0V ↔ 15V<br>V <sub>CC</sub> = 300V, I <sub>C</sub> = 50A<br>T <sub>j</sub> = 125°C, Inductive Load Fig.3 | 0.8                    | 1.2  | 2.4  | μs   |    |
|                                      | t <sub>rr</sub>      |   | —                      | 0.15 | 0.3  |      |    |
|                                      | t <sub>c(on)</sub>   |   | —                      | 0.4  | 1.0  |      |    |
|                                      | t <sub>off</sub>     |   | —                      | 2.0  | 2.8  |      |    |
|                                      | t <sub>c(off)</sub>  |   | —                      | 0.6  | 1.2  |      |    |
| Collector-Emitter Cutoff Current     | I <sub>CES</sub>     | V <sub>CE</sub> = V <sub>CES</sub><br>V <sub>D</sub> = 15V Fig.4  | T <sub>j</sub> = 25°C  | —    | —    | 1    | mA |
|                                      |                      |   | T <sub>j</sub> = 125°C | —    | —    | 10   |    |

## Control Part

| Item                                    | Symbol               | Condition   | Min.                               | Typ. | Max. | Unit |    |
|---|----------------------|---|------------------------------------|------|------|------|----|
| Circuit Current                         | I <sub>D</sub>       | V <sub>D</sub> = 15V<br>V <sub>CIN</sub> = 15V  | V <sub>N1</sub> -V <sub>NC</sub>   | —    | 20   | 30   | mA |
|   |                      |   | V <sub>XP1</sub> -V <sub>XPC</sub> | —    | 6    | 10   |    |
| Input ON Threshold Voltage              | V <sub>th(ON)</sub>  | Applied between : U <sub>P</sub> -V <sub>UPC</sub> , V <sub>P</sub> -V <sub>VPC</sub><br>W <sub>P</sub> -V <sub>WPC</sub> , U <sub>N</sub> -V <sub>NC</sub> , W <sub>N</sub> -V <sub>NC</sub> | 1.2                                | 1.5  | 1.8  | V    |    |
| Input OFF Threshold Voltage             | V <sub>th(OFF)</sub> |   | 1.7                                | 2.0  | 2.3  |      |    |
| Short Circuit Trip Level                | SC                   | -20 ≤ T <sub>j</sub> ≤ 125°C Fig.5,6<br>V <sub>D</sub> = 15V Fig.5,6  | 100                                | 132  | —    | A    |    |
| Short Circuit Current Delay Time        | t <sub>off(SC)</sub> | V <sub>D</sub> = 15V Fig.5,6  | —                                  | 10   | —    | μs   |    |
| Over Temperature Protection             | OT                   | Detect T <sub>j</sub> of IGBT chip  | Trip level                         | 135  | 145  | 155  | °C |
|   | OTr                  |   | Reset level                        | —    | 125  | —    |    |
| Supply Circuit Under-Voltage Protection | UV                   | -20 ≤ T <sub>j</sub> ≤ 125°C  | Trip level                         | 11.5 | 12.0 | 12.5 | V  |
|   | UVr                  |   | Reset level                        | —    | 12.5 | —    |    |
| Fault Output Current                    | I <sub>FO(H)</sub>   | V <sub>D</sub> = 15V, V <sub>CIN</sub> = 15V<br>(Note-2)  | —                                  | —    | 0.01 | mA   |    |
|   | I <sub>FO(L)</sub>   |   | —                                  | 10   | 15   |      |    |
| Minimum Fault Output Pulse Width        | t <sub>FO</sub>      | V <sub>D</sub> = 15V (Note-2)   | 1.0                                | 1.8  | —    | ms   |    |

(Note-2) Fault output is given only when the internal SC, OT &amp; UV protections schemes of either upper or lower arm device operate to protect it.

Mechanical Ratings and characteristics

| Item            | Symbol | Condition                 | Min. | Typ. | Max. | Unit  |
|-----------------|--------|---------------------------|------|------|------|-------|
| Mounting torque | —      | Main terminal screw : M 5 | 2.5  | 3.0  | 3.5  | N · m |
| Mounting torque | —      | Mounting part screw : M 5 | 2.5  | 3.0  | 3.5  | N · m |
| Weight          | —      | —                         | —    | 300  | —    | g     |

Recommended Conditions For Use

| Item                            | Symbol         | Condition   | Recommended value | Unit  |
|---------------------------------|----------------|---|-------------------|-------|
| Supply Voltage                  | $V_{CC}$       | Applied across P-N terminals  | $\leq 400$        | V     |
| Control Supply Voltage          | $V_D$          | Applied between : $V_{UP1}-V_{UPC}$<br>$V_{VP1}-V_{VPC}$ , $V_{WP1}-V_{WPC}$ , $V_{N1}-V_{NC}$ (Note-3) | $15.0 \pm 1.5$    | V     |
| Input ON Voltage                | $V_{CIN(ON)}$  | Applied between : $U_P-V_{UPC}$ , $V_P-V_{VPC}$<br>$W_P-V_{WPC}$ , $U_N \cdot V_N \cdot W_N - V_{NC}$   | $\leq 0.8$        | V     |
| Input OFF Voltage               | $V_{CIN(OFF)}$ |   | $\geq 4.0$        |       |
| PWM Input Frequency             | $f_{PWM}$      | Using Application Circuit of Fig.8  | $\leq 20$         | kHz   |
| Arm Shoot-through Blocking Time | $t_{dead}$     | For IPM's each input signals Fig.7  | $\geq 2.0$        | $\mu$ |

(Note-3) With ripple satisfying the following conditions  
 $dv/dt$  swing  $\leq \pm 5V/\mu s$ , Variation  $\leq 2V$  peak to peak

Precautions for testing

1. Before applying any control supply voltage ( $V_D$ ), the input terminals should be pulled up by resistores, etc. to their corresponding supply voltage and each input signal should be kept off state. After this, the specified ON and OFF level setting for each input signal should be done.
2. When performing "SC" tests, the turn-off surge voltage spike at the corresponding protection operation should not be allowed to rise above  $V_{CES}$  rating of the device.  
 ( These test should not be done by using a curve tracer or its equivalent. )

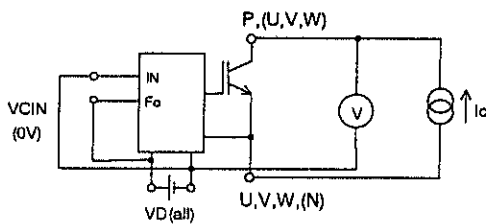

Fig.1  $V_{CE(sat)}$  Tset

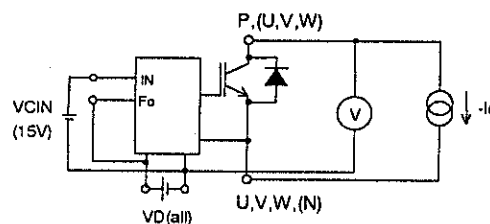

Fig.2  $V_{EC}$  Tset

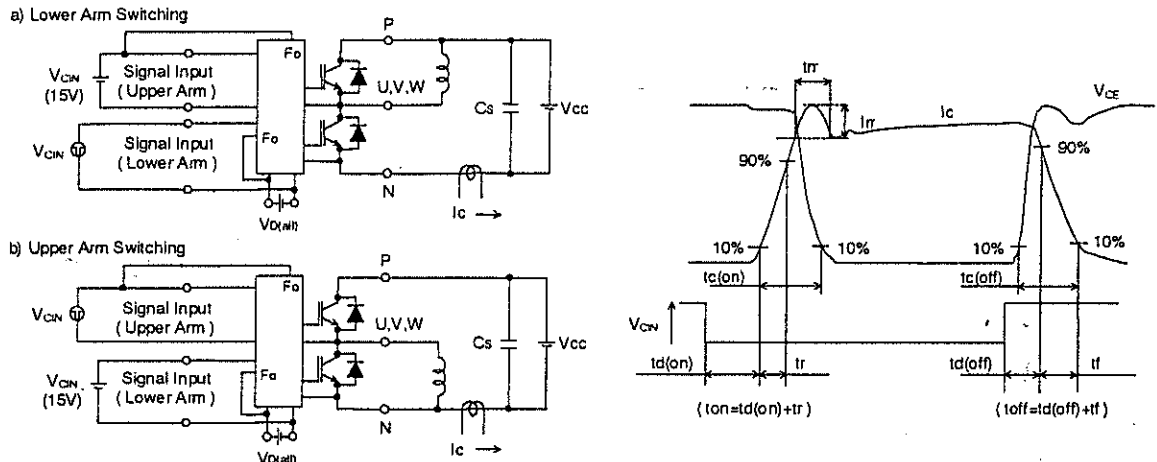

Fig.3 Switching time test circuit and waveform

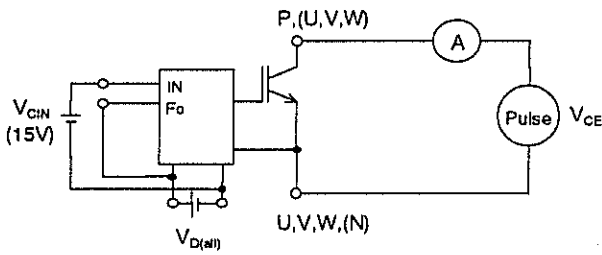

Fig.4 ICES Test

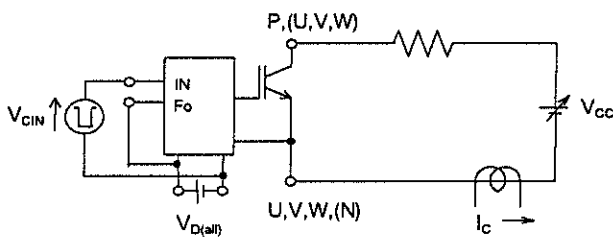

Fig.5 SC Test

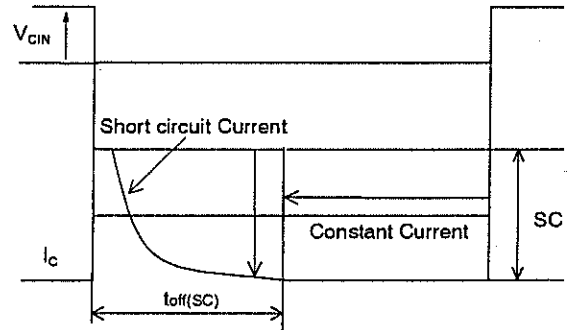
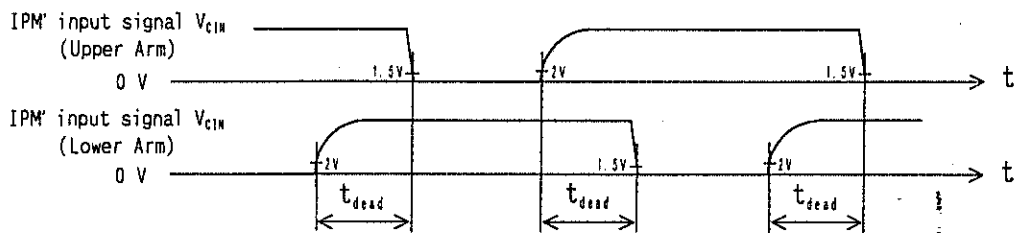

Fig.6 SC Test waveform



1.5V: Input on threshold voltage  $V_{th(on)}$  typical value, 2V: Input off threshold voltage  $V_{th(off)}$  typical value

Fig.7 Dead time measurement point example

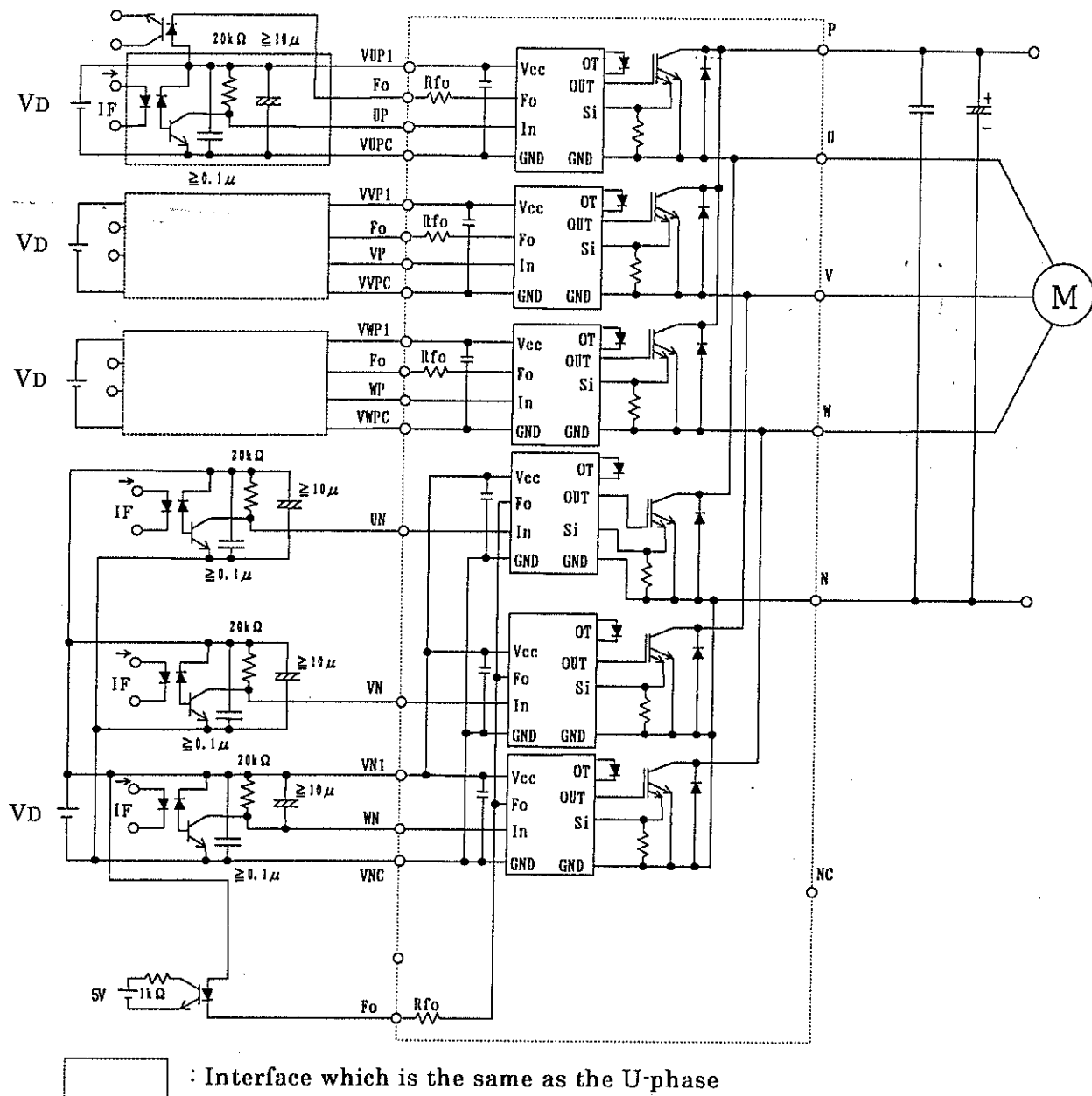

Fig. 8 Application Example Circuit

Notes for stable and safe operation ;

- Design the PCB pattern to minimize wiring length between opto-coupler and IPM's input terminal, and also to minimize the stray capacity between the input and output wirings of opto-coupler.
- Connect low impedance capacitor between the Vcc and GND terminal of each fast switching opto-coupler.
- Fast switching opto-couplers :  $t_{PLH}, t_{PHL} \leq 0.8 \mu s$ , Use High CMR type.
- Slow switching opto-coupler :  $CTR > 100\%$
- Use 4 isolated control power supplies ( $V_D$ ). Also, care should be taken to minimize the instantaneous voltage charge of the power supply.
- Make inductance of DC bus line as small as possible, and minimize surge voltage using snubber capacitor between P and N terminal.
- Use line noise filter capacitor ( ex. 4.7nF ) between each input AC line and ground to reject common-mode noise from AC line and improve noise immunity of the system.

Outline drawings

[Dimensions in mm]

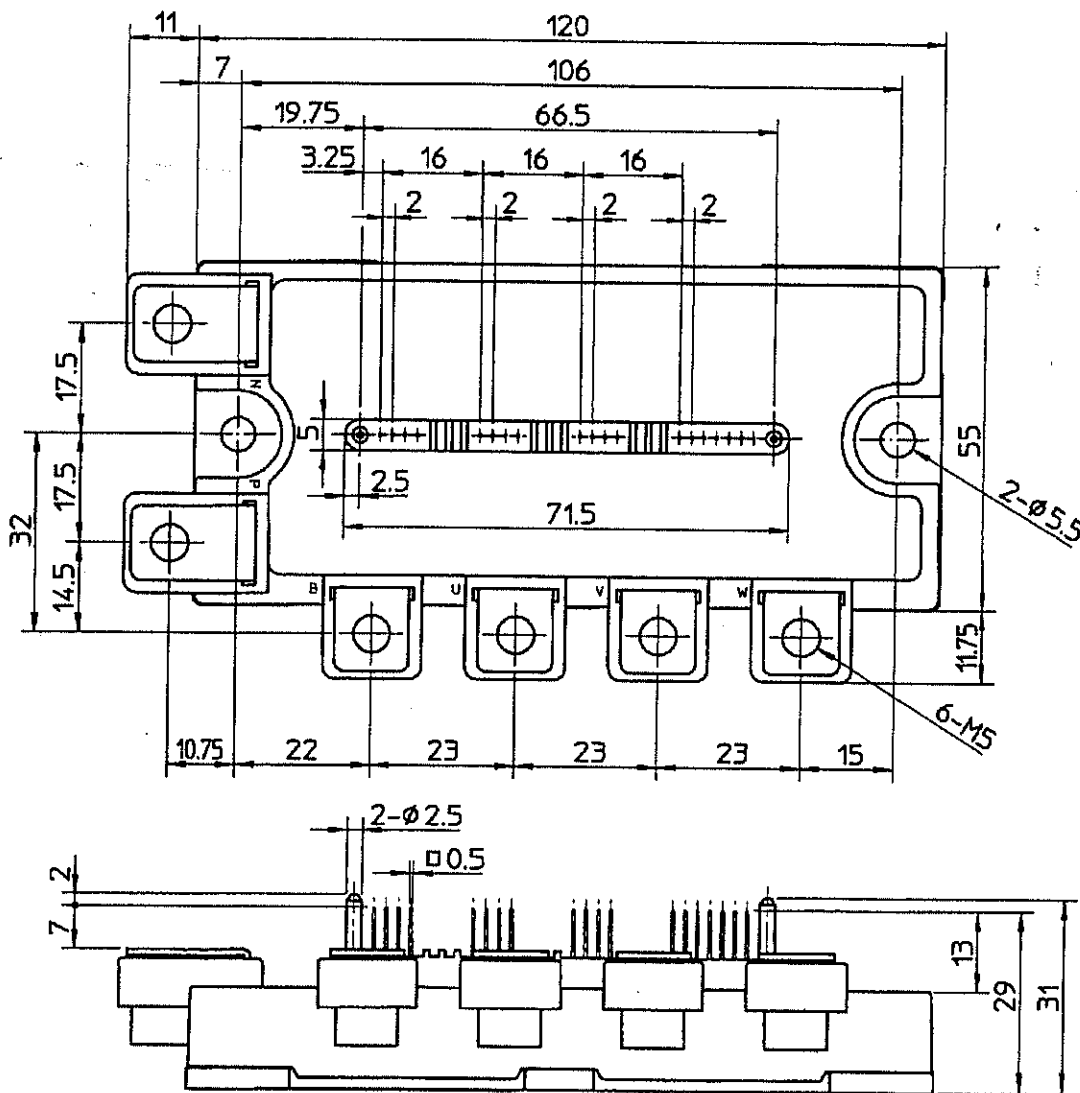

Terminal code

|         |         |          |        |
|---------|---------|----------|--------|
| 1. VUPC | 6. VFO  | 11. WP   | 16. UN |
| 2. UFO  | 7. VP   | 12. VWP1 | 17. VN |
| 3. UP   | 8. VVP1 | 13. VNC  | 18. WN |
| 4. VUP1 | 9. VWPC | 14. VN1  | 19. Fo |
| 5. VVPC | 10. WFO | 15. NC   |        |

